

Multi-Fit Wheels vs. OEM Fit Wheels

Ninety Nine percent of all vehicles out in the world today utilize a "hub centric" rim.

Multi-fit wheels are what they call "lug centric" versus most OEM wheels being "hub centric." That's where the **centre bore** measurement comes in.

CENTRE BORE: On a multi-fit rim, this distance is made as large as possible to fit as many vehicles as possible

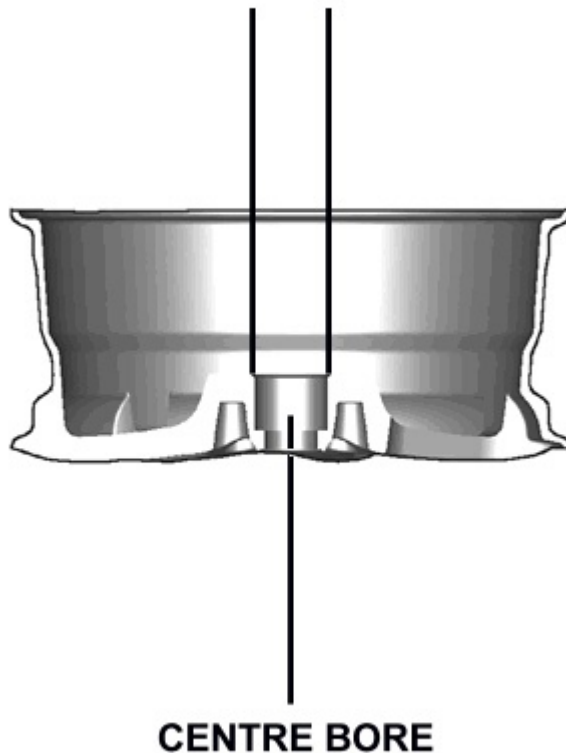

On a hub centric setup (OEM* fitted), the wheel rests on the hub, and are held in place by the lug nuts. In this case, they are centered by the wheel hubs. In a lug centric setup (Multi-Fit), the centre bore is much bigger than the hub, so the wheel does not rest on the hub, and is held, supported and centered entirely by the lugs.

In general, the hole in the centre of a multi-fit wheel is made as large as possible so it can fit all wheel hubs for the various vehicles they may be used on, hence "multi" fit.

A wheel should be centered on the wheel hub by the hole fitting snugly on the hub. The wheel nuts then hold the wheel on the hub. Without this centering action, over time the wheel can shift slightly and the wheel feels out of balance or out of round. This will cause excessive wearing on your tires and will dramatically decrease the life of them.

What that means is that when your tire/wheel combination is being balanced by a tire shop, they utilize a balance machine that relies on the hub of the rim to be a "true centering" aid. In other words, the center hole of the rim is what the tire shop uses to base the tire/wheel combination balance on.

The balance problem of Multi-fit wheels has slowed their use and manufacture considerably and many garages avoid even selling them as they are bound to have these problems. There are not many multi-fit wheels on the market as most tire shops only use proper OEM fitted wheels made for the car on which they will be installed.

We highly recommend OEM fitted wheels that are sized specifically for the year and make of your vehicle for a much smoother ride overall and thus avoid the known balancing issues of the multi-fit wheels. With OEM fitted wheels, your tires are likely to last much longer.

*OEM's are the industry's brand name [auto manufacturers](#), such as [General Motors](#), [Ford](#), [Toyota](#), [Volkswagen](#), etc. The OEM definition in the automobile industry constitutes a federally-licensed entity required to warrant and/or guarantee their products, unlike "aftermarket" which is not legally bound to a government-dictated level of liability.